

DESCRIPTION

This is a Silicon P-Type PIN Quadrant detector designed for use in precision guidance and laser tracking and alignment applications.

FEATURES

- High Responsivity @ 1.06 μm , 0.45 A/W typical
- Sensitivity range 600-1100 nm
- Four Quadrant Geometry w/guard ring
- 14 mm Diameter Active Area

ABSOLUTE MAXIMUM RATINGS

- Storage temperature..... -65°C to +125°C
- Case operating temperature... -55°C to +100°C
- Lead solder temperature..... 260°C, 10 seconds
- Supply Voltage..... +250 Volts

OPERATING CONDITIONS

- Supply Voltage..... 180 Volts
- Forward Voltage..... 0.5 Volts
- Power Dissipation (per quadrant, 25°C).. 500 mW
- Noise Current..... 0.5×10^{-12} A/Hz

ELECTRO-OPTICAL CHARACTERISTICS (Case T = 25°C)

PARAMETER	TEST CONDITION	SYMBOL	MIN	TYP	MAX	UNIT
Breakdown Voltage	$I_R = 100 \mu\text{A}, H = 0 \text{ mW/cm}^2$	V_{BR}	250			Volts
Dark Current	$V_R = 180\text{V}, H = 0 \text{ mW/cm}^2$	I_D		100	1000	nA
Capacitance	$V_R = 180\text{V}, f = 1 \text{ MHz}$	C_T		12	20	pF
Crosstalk	$V_R = 180\text{V}$				1	%
Response Time	10%-90%, $\lambda = 1.06 \mu\text{m}$ $V_R = 180 \text{ V}, R_L = 50 \Omega$	t_r		12	15	nsec
		t_f		12	20	nsec
Responsivity	$V_R = 180\text{V}, \lambda = 1.06 \mu\text{m}$	R_e	0.36	0.45		A/W

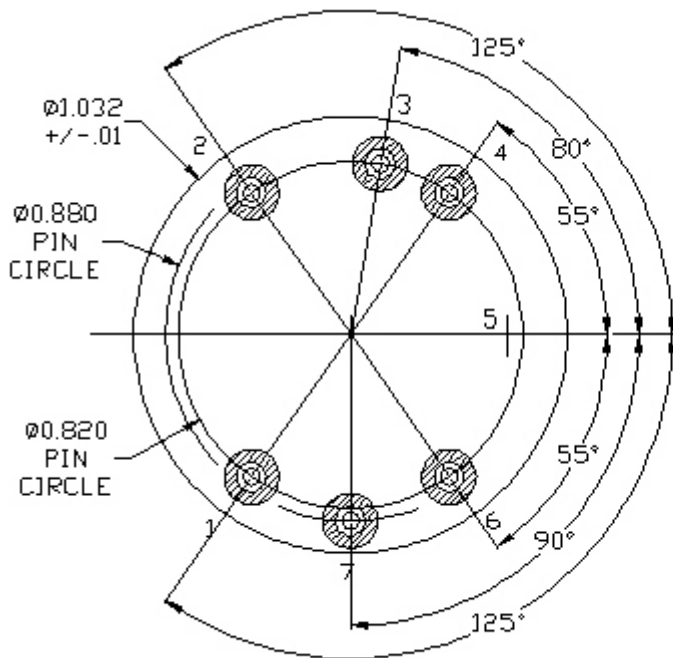
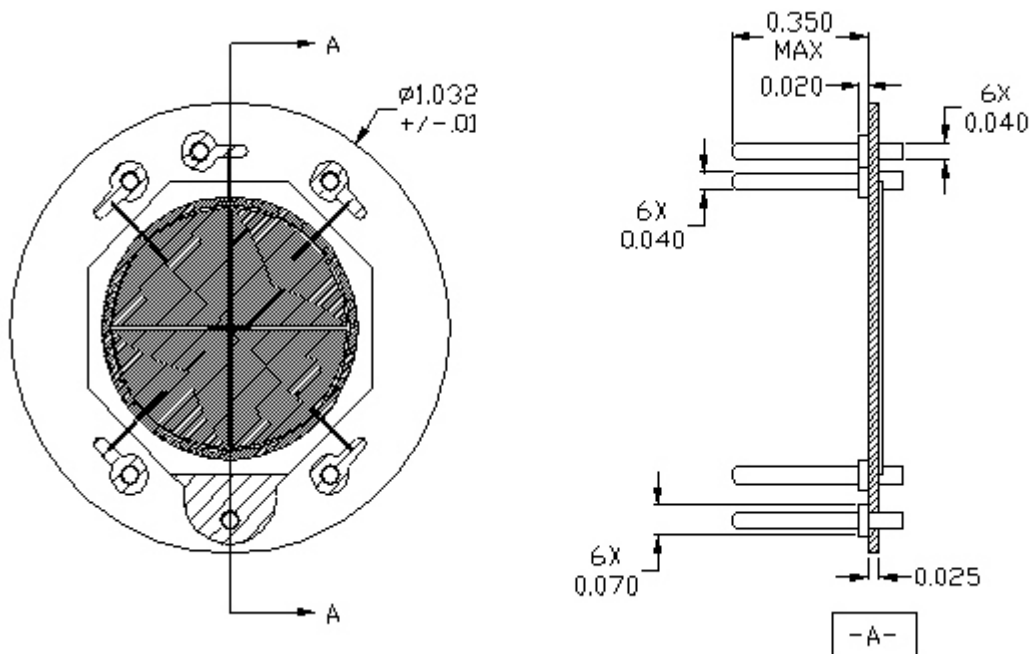

Bottom View

Device Pinout:

- Pin 1: Cathode 1
- Pin 2: Cathode 2
- Pin 3: Guard Ring Cathode
- Pin 4: Cathode 3
- Pin 5: No Connection
- Pin 6: Cathode 4
- Pin 7: Common Anode