

**DESCRIPTION**

This is a high radiance 567 nm Green LED optimized for applications requiring high luminous intensity and sunlight visibility.

**FEATURES**

- 567 nm Green
- High luminous intensity, 100 mcd typical
- High Reliability
- Hermetic Package
- 12 Degree Half angle of light emission
- Similar to 1N6611
- Available screened to MIL-PRF-19500/521

**ABSOLUTE MAXIMUM RATINGS**

- Storage temperature..... -65°C to +125°C
- Case operating temperature -65°C to +100°C
- Lead solder temperature.... 260°C, 10 seconds
- Continuous forward current..... 35 mA
- Peak Forward Current..... 1 A  $\sqrt{1}$
- Reverse Voltage..... 5 Volts

$\sqrt{1}$  1 μsec pulse width, 300 Hz

**OUTLINE DIMENSIONS**

Tolerances are +/-0.005 inches, except as noted

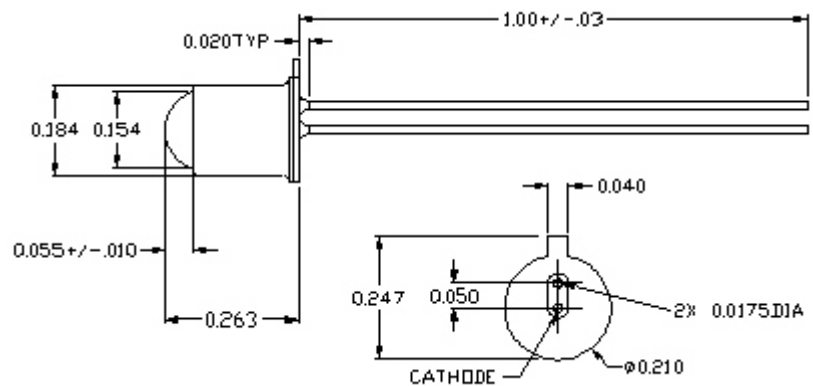

**Pinout**

- 1. Cathode 2. Anode

The case is electrically isolated from the pins.

**ELECTRO-OPTICAL CHARACTERISTICS (Case T = 25°C)**

PARAMETER	TEST CONDITION	SYMBOL	MIN	TYP	MAX	UNIT
Forward Voltage	If = 25 mA	V <sub>f</sub>		2.3	3.0	Volts
Reverse Current	V <sub>r</sub> = 3V	I <sub>r</sub>	1.0			μA
Half Angle at Half Power		θ <sub>1/2</sub>		12		DEG
Capacitance	V <sub>r</sub> = 0 V, f = 1 MHz	C		100		pF
Luminous Intensity 1	If = 25 mA, 0 degrees	I <sub>v1</sub>	20	100		mcd
Luminous Intensity 2	If = 25 mA, 30 degrees	I <sub>v2</sub>	1.5			mcd
Peak Wavelength	If = 25 mA	λ <sub>p</sub>	555	567	580	nm