

DESCRIPTION

This is a high radiance GaAlAs IR LED optimized for fiber optic applications requiring high power and a fast response time.

FEATURES

- Internal lensing for efficient fiber coupling
- High Electrical Bandwidth/Fast response time
- High Reliability
- Hermetic Package
- Similar to Honeywell HFE 4050

ABSOLUTE MAXIMUM RATINGS

- Storage temperature..... -65°C to +150°C
- Case operating temperature.... -55°C to +100°C
- Lead solder temperature..... 260°C, 10 seconds
- Continuous forward current..... 100 mA
- Reverse Voltage..... 1 Volt

OUTLINE DIMENSIONS

All dimensions are in inches (except as noted)

Pinout

1. Anode
2. Cathode
3. Case (Ground)

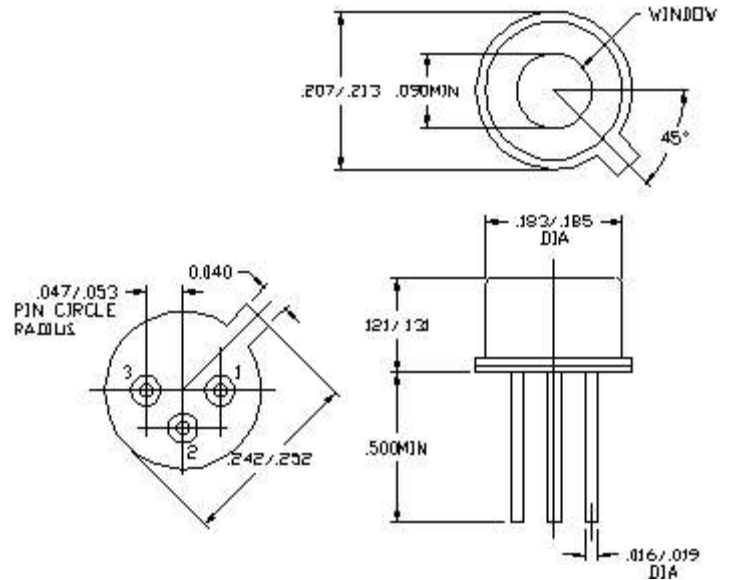

ELECTRO-OPTICAL CHARACTERISTICS (Case T = 25°C)

PARAMETER	TEST CONDITION	SYMBOL	MIN	TYP	MAX	UNIT
Forward Voltage	I _f = 100 mA	V _f	1.5	1.6	2.25	Volts
Reverse Voltage	I _r = 10 μA	BVR	1.0	5.0		Volts
Series Resistance	DC	R _s		2.0		Ohms
Capacitance	V _r = 0 V, f = 1 MHz	C		70		pF
Fiber Coupled Power	I _f = 100 mA, 50 μm Core dia, .21 NA	P _{oc}	30			μW
Fiber Coupled Power	I _f = 100 mA, 100 μm Core dia, .28 NA	P _{oc}	125	200		μW
Total Optical Power	I _f = 100 mA	P _{out}		3.5		mW
Response Time	10%-90%, 1V Prebias I _f = 100 mA	t _r		4	10	nsec
		t _f		6	10	nsec
Peak Wavelength	I _f = 100 mA	λ _p	810	850	885	nm
Spectral Bandwidth	I _f = 100 mA	Δλ		50		nm
Electrical Bandwidth	I _f = 100 mA	BWE		85		MHz